



KNIFE-GATE VALVES

L SERIES

ELECTRIC ACTUATOR

- This actuator is automatic and includes the following parts:
 - Electric motor
 - Stem
 - Yoke
- The electric motor includes:
 - Emergency manual handwheel.
 - Limit switches.
 - Torque switches.
- Options:
 - Different types and brands.
 - Non-rising stem.
- ISO 5210 / DIN 3338 Flanges.
- Available: ND50 to ND2000, other ND on request.
- **A = Max. width** of the valve (without actuator).
- **B = Max. height** of the valve (without actuator).
- **C = maximum length** when the gate is centred.
- From DN500 the motor is assisted with a gear box.
- The weights are approximate and vary according to the material and the valve's accessories.

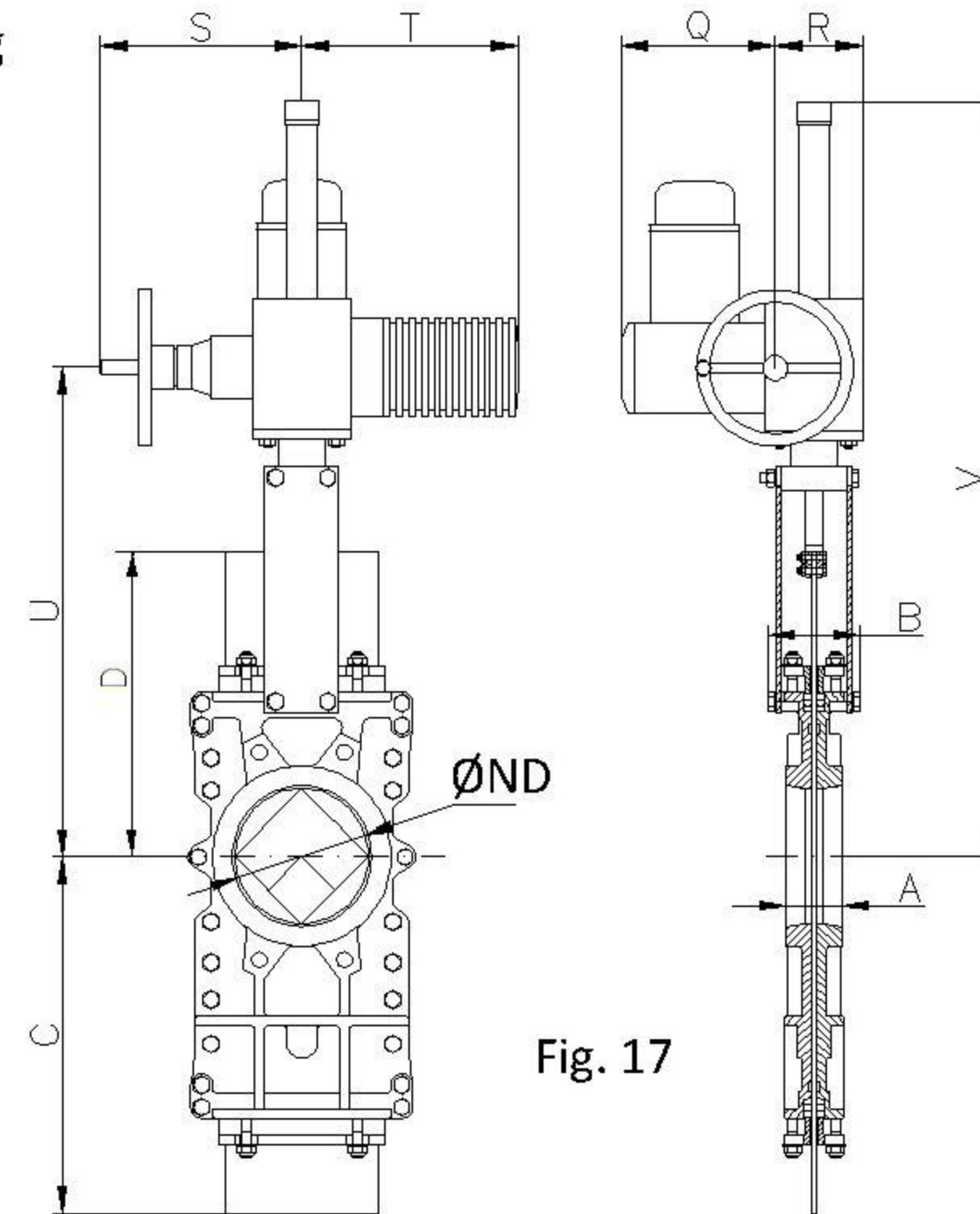

Fig. 17

ND	ΔP (Kg/cm ²)	DRAW (Nw)	TORQUE (Nm)	A	B	C	D	Q	R	S	T	U	V	Weight (kg.)
50	10	894	2.1	40	91	225	243	197	102	234	265	347	587	32
65	10	1508	3.5	40	91	265	269	197	102	234	265	374	614	33
80	10	2281	5.2	50	91	310	293	197	102	234	265	400	640	37
100	10	3561	8.2	50	91	370	334	197	102	234	265	440	680	39
125	10	5565	13	50	101	430	367	197	102	234	265	473	713	48
150	10	6419	15	60	101	495	419	197	102	234	265	525	765	58
200	8	10020	29	60	118	630	525	197	102	234	265	640	880	74
250	6	11230	32.5	70	118	770	620	197	102	234	265	741	981	108
300	6	16210	47	70	118	895	726	197	102	234	265	841	1141	132
350	5	17740	70	96	290	1050	780	197	115	256	282	944	1347	189
400	5	23260	92	100	290	1185	855	197	115	256	282	1050	1550	261
450	3	22260	89	106	290	1320	975	222	153	325	385	1147	1847	368
500	3	27470	110	110	290	1455	1064	222	153	325	385	1259	1959	497
600	3	39850	160	110	290	1720	1244	222	153	325	385	1465	2165	584
700	2	36880	212	110	320	1995	1425	222	153	325	385	1651	2451	988
800	2	48980	285	110	320	2230	1615	222	153	332	385	1865	2665	N.G.
900	2	61230	353	110	320	2465	1823	222	153	332	385	2098	2998	N.G.
1000	2	77690	457	110	320	2620	1992	222	153	332	385	2288	3178	N.G.
1100	2	95506	674	150	340	3030	2217	227	195	355	510	2575	3675	N.G.
1200	2	113710	802	150	340	3250	2351	227	195	355	510	2866	4042	N.G.
1300	2	133563	943	150	390	3430	2882	227	195	355	510	3082	4382	N.G.
1400	2	157280	1298	150	390	3680	3250	222	153	332	385	3395	4852	N.G.
1500	2	180712	1493	170	426	3930	3517	222	153	332	385	3662	5217	N.G.
1600	2	205780	1904	170	426	4272	3775	227	195	355	510	3975	5575	N.G.
1700	2	236498	2214	190	440	4615	4008	227	195	355	510	4210	5908	N.G.
1800	2	264860	2477	190	440	4886	4242	227	195	355	510	4590	6490	N.G.
1900	2	299502	3213	210	480	5158	4390	227	195	355	510	4590	6490	N.G.
2000	2	331260	3549	210	480	5430	4540	227	195	355	510	4740	6740	N.G.

N.G.: Weight not given

table 10